

MOTOR SPECIFICATION SHEET

MODEL : SF-J 25HP 2P (LT)

USED FOR : STANDARD

DESCRIPTION	DETAIL				
PHASE	3				
MODEL NAME	SF-J				
RATED OUTPUT, HP (kW)	25 (18.5)				
POLE	2				
CODE	MEATH CODE : 1M002F-201850J-FY1				
OUTLINE DRAWING NO.	OMM34O022-C				
RATED VOLTAGE (V)	220	380	415	220	440
RATED FREQUENCY (Hz)	50	50	50	60	60
RATED CURRENT (A)	59	34	33	57	29
RATED SPEED (min ⁻¹)	2910	2910	2930	3490	3510
THERMAL CLASS	155(F)				
RATING	S1 (CONTINUOUS)				
ENCLOSURE CONSTRUCTION	TOTALLY ENCLOSED FAN COOLED				
DEGREES OF PROTECTION	IP55				
METHOD OF COOLING	IC411				
FRAME NO.	160L				
WEIGHT (kg)	145				
STANDARD	IEC 60034-1, JEC-2137-2000				
INSTALLATION	FOOT MOUNTED				
ROTATION	CCW (VIEWED FROM SHAFT END)				
BEARING	LOAD SIDE : 6309ZZ				
	OPPOSITE SIDE : 6308ZZ				
BEARING GREASE	UREA GREASE				
NOISE (dB.A)	90				
VIBRATION	V15				
CIRCUMSTANCE CONDITION	AMBIENT TEMPERATURE : -20 ~ +40°C				
	AMBIENT HUMIDITY : 95%RH OR LESS				
	ABOVE SEA LEVEL : 1000m OR LESS				
	ENVIRONMENT : NO BURSTING/EROSIVE GAS OR VAPOR				
COLOR	MUNSELL N5.5 (GRAY)				
TERMINAL BOX	NO. OF LEAD WIRES : 6				
	SOURCE CONNECTION : LEAD WIRES				
INSULATION RESISTANCE	BY DC 500V MEGGER - ≥100MΩ				
DIELECTRIC TEST	AC 50Hz 1800V - 1min. (Based on rated voltage 380V)				
SHAFT SWING	≤0.05mm				
MATERIAL	FRAME : CAST IRON				
	BRACKET : CAST IRON				
	SHAFT : CARBON STEEL				
	STATOR CORE : ELECTRICAL STEEL				
	WIRE : ENAMELLED COPPER MAGNET WIRE				
	INSULATOR : POLYESTER FILM SATURATED WITH RESIN				
	VARNISH : EPOXY DENATURALIZATION POLYESTER				
	ROTOR CORE : ELECTRICAL STEEL				
	CONDUCTOR : ALUMINIUM				
	TERMINAL BOX : STEEL PLATE				
	PAINTING : POLYURETHANE RESIN				
PRODUCTION COUNTRY	THAILAND				

Specifications subject to change without notice.

SPECIFICATION SHEET NO.

SS-M-3139-B

MODEL SF-J THREE PHASE INDUCTION MOTOR OUTLINE DRAWING

TOTALLY ENCLOSED FAN COOLED TYPE
 DEGREES OF PROTECTION IP55
 DUST & WATER JET PROOF

CUSTOMER _____
 USER _____
 FOR _____
 CUSTOMER'S ORDER NO. _____
 QUANTITY _____
 MFG. ORDER NO. _____

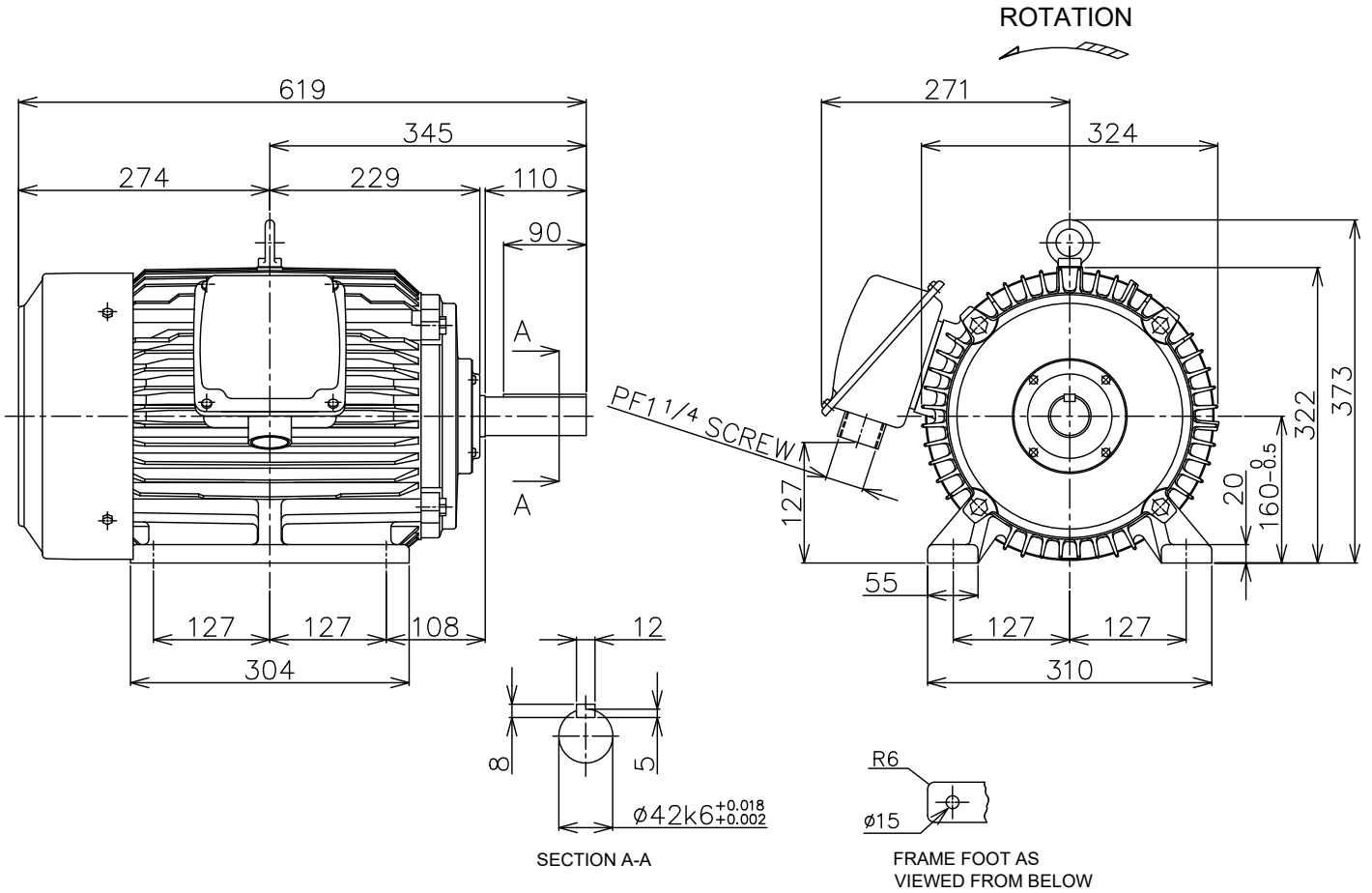

FRAME SIZE	RATING	TH. CLASS	AMB. TEMP.	BEARINGS		COLOR	DIRECTION OF ROTATION	NO. OF LEAD WIRES	REMARKS
				LOAD SIDE	OPP. SIDE				
160L	S1 (CONT.)	155(F)	40°C	6309ZZ	6308ZZ	GRAY (MUNSELL N5.5)	CCW	6	

YOUR ORDER	OUTPUT		POLES	VOLT	HERTZ	REMARKS
	HP	KW				
	25	18.5	2	220/380/415	50	LT
				220/440	60	
	20	15	4	220/380/415	50	LT
				220/440	60	
	15	11	6	220/380/415	50	LT
				220/440	60	
	25	18.5	2	380/415	50	HT
				380/440	60	
	20	15	4	380/415	50	HT
				380/440	60	
	15	11	6	380/415	50	HT
				380/440	60	

MITSUBISHI ELECTRIC AUTOMATION (THAILAND) CO., LTD.

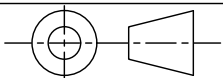

DIMENSION IN mm.
 SCALE : NTS

OUTLINE DRAWING NO.

0 M M 3 4 0 0 2 2

REV.

C